

2: 1 Wide voltage input, isolated, regulated single-output, DIP package

**FEATURES**

- Wide voltage input of 2:1
- Isolation voltage: 1500 VDC
- Sustainable short-circuit protection
- High conversion efficiency
- Operating temperature range: -40 to +85°C
- Complies with EN62368 certification standard



V06-B\_Y series is an international standard through-hole DIP package, mainly used for: Industrial control circuits, power electronics, instrumentation, communication circuits, etc.

**SELECTION TABLE**

Part No	Input voltage(VDC)		Output voltage (VDC)	Output current		Efficiency (%)	Capacitive load (uF)
	Typ	Range		Min (mA)	Max(mA)		
V06-B1203Y			3.3	0	1500	78	1800
V06-B1205Y			5	0	1200	81	1000
V06-B1212Y	12	9~18	12	0	500	84	470
V06-B1215Y			15	0	400	85	220
V06-B1224Y			24	0	250	85	100
V06-B2403Y			3.3	0	1500	77	1800
V06-B2405Y			5	0	1200	82	1000
V06-B2412Y	24	18~36	12	0	500	85	470
V06-B2415Y			15	0	400	86	220
V06-B2424Y			24	0	250	85	100
V06-B4803Y			3.3	0	1500	78	1800
V06-B4805Y			5	0	1200	83	1000
V06-B4812Y	48	36~75	12	0	500	86	470
V06-B4815Y			15	0	400	87	220
V06-B4824Y			24	0	250	86	100

**INPUT**

Item	Conditions/Description		Min	Typ	Max	Units
Input Current	Full Load/No Load	12VDC input	/	615/10	640/25	mA
		24VDC input	/	290/7	320/15	
		48VDC input	/	145/7	160/10	
Refracted ripple current			/	20	/	
Surge voltage	Maximum 1 second	12VDC input	-0.7	/	25	VDC
		24VDC input	-0.7	/	50	
		48VDC input	-0.7	/	100	
Input filter type	Capacitance filter					
Hot Plug	Not supported					

**OUTPUT**

Item	Conditions/Description	Min	Typ	Max	Units
Output voltage accuracy	Load change from 5% to 100%	/	±1	±3	
Line regulation	Full load, input voltage variation ±1%	/	±0.2	±1	%
Load regulation	Load change from 5% to 100%	/	±0.5	±1.5	
Transient recovery time	25% load step change	/	0.3	0.5	ms
Transient response deviation		/	±3	±8	%
Ripple and noise <sup>1</sup>	20MHz bandwidth (peak to peak)	/	70	/	mVp-p
Temperature coefficient	100% load	/	±0.03	/	%/°C
Output overvoltage protection		110	/	160	%Vo
Output overcurrent protection	Input voltage range	110	140	190	%Io
Short circuit protection		Continuous, self-recovery			

Notes:

1. ripple and noise are measured at 20 MHz BW by "parallel cable" method with 1 μF ceramic and 10 μF electrolytic capacitors on the output.

**COMPREHENSIVE**

Item	Conditions/Description	Min	Typ	Max	Units
Isolation voltage	input to output for 1 minute at 1 mA max.	1500	/	/	VDC
Isolation resistance	Input to output, insulation voltage 500 VDC	1000	/	/	MΩ
Isolation capacitor	Input-Output, 100kHz/0.1V	/	1000	/	pF
Operating temperature	Use with derating when temperature is ≥71°C, see derating curve chart 1	-40	/	85	
Storage temperature		-40	/	125	°C
Working shell temperature rise	at full load, Ta=25°C	/	25	/	
Welding Temperature	Manual-welding, Operation time 3-5 seconds	/	/	300	
	Wave soldering, Operation time 5-10 seconds	/	/	260	
Storage humidity	non-condensing	5	/	95	%
Switching frequency	Full load, input nominal voltage	/	300	/	KHz
MTBF	MIL-HDBK-217F @ 25°C	/	1000	/	Khours
Cooling method	Natural air cooling				
Dimensions	25.40 x 25.40 x 11.70mm (1.000 x 1.000 x 0.461 inch)				
Weight	12.5g (Typ.)				
Case material	Aluminum alloy				

**EMC**

Item	Conditions/Description	
EMI	CE	CISPR32/EN55032 CLASS B (For recommended circuits, see Figure 3-②)
	RE	CISPR32/EN55032 CLASS B (For recommended circuits, see Figure 3-②)
EMS	Electrostatic Discharge	IEC/EN61000-4-2 Contact ±4kV perf. Criteria B
	Radiated Immunity	IEC/EN61000-4-3 10V/m perf. Criteria A
	Pulse group Immunity	IEC/EN61000-4-4 ±2kV(For recommended circuits, see Figure 3-①) perf. Criteria B
	Surge Immunity	IEC/EN61000-4-5 line to line ±2kV (For recommended circuits, see Figure 3-①) perf. Criteria B
	Conducted disturbance immunity	IEC/EN61000-4-6 3 Vr.m.s perf. Criteria A
	Voltage dips, and short-term interruptions immunity	IEC/EN61000-4-29 0%-70% perf. Criteria B

**Product characteristic curve**

( Figure 1 ) Temperature curve

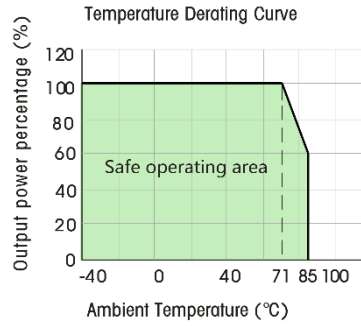

**Design reference**

**1. General application circuits**

All DC/DC converters in this series are tested according to the generally recommended circuit (as shown in Figure 2) before leaving the factory.

If further reduction of input and output ripple is required, the external filter capacitors Cin and Cout connected to the input and output terminals can be appropriately increased in capacitance, but the capacitance value should not exceed the maximum capacitive load of the product, otherwise it may cause startup issues. Under the condition of ensuring safe and reliable operation, the recommended capacitance values are as follows (Table 1). For applications with actual output power less than 0.5W, it is recommended not to connect external capacitors.

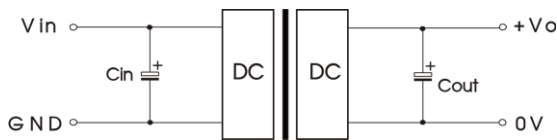

(Figure 2)

Input voltaq(Vdc)	12	24	48
Cin	100uF/50V	10-47uF/50V	100uF/100V
Cout	3.3/5Vdc	10uF/16V	
	12/15Vdc	10uF/25V	
	24Vdc	10uF/50V	

(Table 1)

**2. EMC Recommended Application Circuits (Parameters are shown in Table 2)**

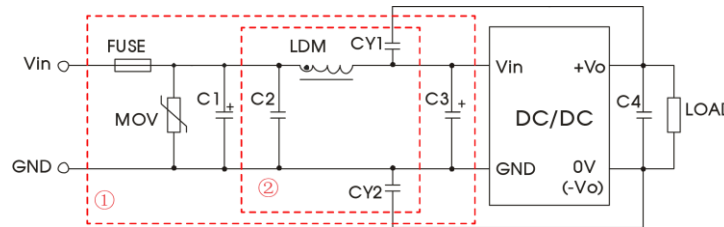

(Figure 3)EMC Recommended Circuit

Vin(VDC)	12	24	48
FUSE	Slow-blow fuse, selected based on the user's actual input current		
MOV	14D330K	14D470K	14D101K
C1	1000μF/35V	1000μF/50V	330μF/100V
C2	1μF/50V	1μF/50V	4.7μF/100V
C3	330μF/35V	330μF/50	330μF/100V
C4	Refer to the Cout parameter in Figure 2		
LDM	4.7μH		
CY1,CY2	1nF/400VAC		

(Table 2) Recommended Application Circuit Parameters of EMC

Note:

1. Part ① in Figure 3 is used for EMS testing; part ② is used for EMI filtering, which can be selected according to requirements;
2. If the component in the diagram does not have parameter descriptions attached, this component is not required in the peripheral circuit of this model.

**Ripple and Noise Testing Reference**

Refer to the following circuit to test ripple and noise

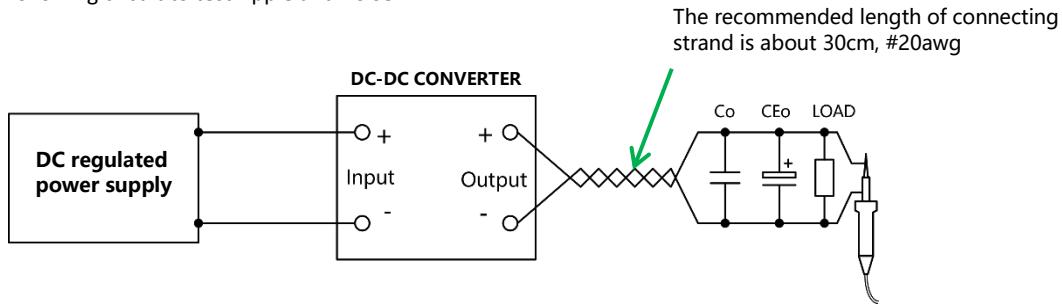

Co	0.1uF ceramic capacitor, the voltage level is 3 times of the output voltage of DC / DC converter.
CEo	10uF electrolytic capacitor, the rated voltage is 1.5 times of the output voltage of DC / DC converter.
LOAD	Resistive load to DC / DC converter shall be connected through stranded wire.

**Note:** since the ground clamp of the oscilloscope will absorb various high-frequency noise interference measurement results, in order to shield the interference, the proximity test method can be used for measurement. The actual test ripple and noise will vary due to different circuits, external components and instruments.

**MECHANICAL DRAWING**

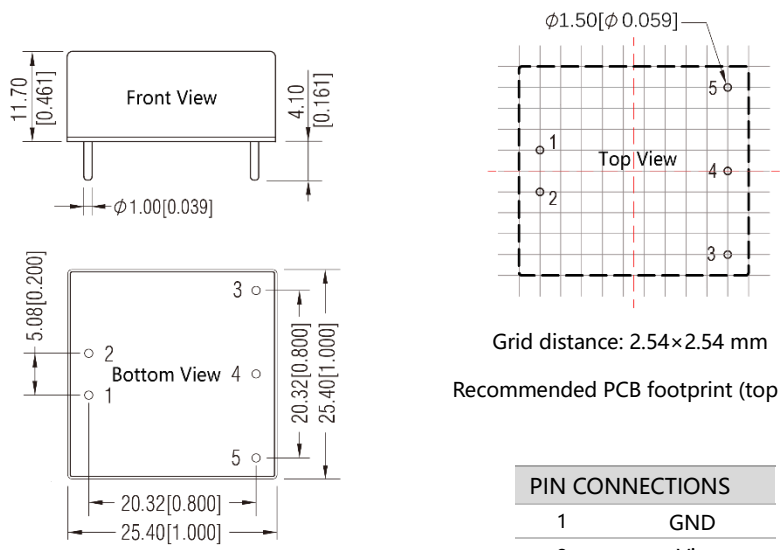

Dimension unit: mm [inch]  
Pin tolerance: ±0.10[±0.004]  
Other tolerances: ±0.50[±0.020]

PIN CONNECTIONS	
1	GND
2	Vin
3	+Vo
4	No Pin
5	0V

- Note:
1. Qituo technology reserves the right to change the product at any time without notice;
  2. The product shall be provided with a 3-year warranty period;
  3. Unless otherwise specified, the products in this manual are not authorized to be used for key components of equipment requiring high reliability, so as not to affect the safety or effectiveness of the device;
  4. All parameters in this manual are measured under indoor  $t_a=25\text{ }^\circ\text{C}$ , humidity <75%, nominal input voltage and output rated load;