

2: 1 Wide voltage input, isolated, regulated single-output DIP package

FEATURES

- Wide voltage input of 2:1
- Isolation voltage: 1500 VDC
- Sustainable short-circuit protection
- High conversion efficiency
- Operating temperature range: -40 to +85°C
- Complies with EN62368 certification standard



V06-B_Z series is an international standard through-hole DIP package, mainly used for: Industrial control circuits, power electronics, instrumentation, communication circuits, etc.

SELECTION TABLE

Part No	Input voltage(VDC)		Output voltage (VDC)	Output current		Efficiency (%)	Capacitive load (uF)
	Typ	Range		Min (mA)	Max(mA)		
V06-B0503Z	5	4.5~9	3.3	0	1500	75	1800
V06-B0505Z			5	0	1200	78	1000
V06-B0509Z			9	0	667	83	680
V06-B0512Z			12	0	500	84	470
V06-B0515Z			15	0	400	84	220
V06-B0524Z			24	0	250	84	100
V06-B1203Z	12	9~18	3.3	0	1500	75	1800
V06-B1205Z			5	0	1200	80	1000
V06-B1209Z			9	0	667	83	680
V06-B1212Z			12	0	500	84	470
V06-B1215Z			15	0	400	85	220
V06-B1224Z			24	0	250	85	100
V06-B2403Z	24	18~36	3.3	0	1500	78	1800
V06-B2405Z			5	0	1200	82	1000
V06-B2409Z			9	0	667	83	680
V06-B2412Z			12	0	500	84	470
V06-B2415Z			15	0	400	85	220
V06-B2424Z			24	0	250	86	100
V06-B4803Z	48	36~75	3.3	0	1500	79	1800
V06-B4805Z			5	0	1200	82	1000
V06-B4809Z			9	0	667	83	680
V06-B4812Z			12	0	500	85	470
V06-B4815Z			15	0	400	88	220
V06-B4824Z			24	0	250	87	100

INPUT

Item	Conditions/Description	Min	Typ	Max	Units	
Input Current	Full Load/No Load	5VDC input	/	1450/10	1580/30	mA
		12VDC input	/	600/7	650/25	
		24VDC input	/	290/7	320/25	
		48VDC input	/	145/7	160/25	
Refracted ripple current		/	50	/		
Surge voltage	Maximum 1 second	5VDC input	-0.7	/	16	VDC
		12VDC input	-0.7	/	25	
		24VDC input	-0.7	/	50	
		48VDC input	-0.7	/	100	
Input filter type	Capacitance filter					
Hot Plug	Not supported					

OUTPUT

Item	Conditions/Description	Min	Typ	Max	Units
Output voltage accuracy	Load change from 5% to 100%	/	±1	±3	
Line regulation	Full load, input voltage variation ±1%	/	±0.2	±0.5	%
Load regulation	Load change from 5% to 100%	/	±0.5	±1.5	
Transient recovery time	25% load step change	/	0.3	0.5	ms
Transient response deviation		/	±3	±8	%
Ripple and noise ¹	20MHz bandwidth (peak to peak)	/	80	/	mVp-p
Temperature coefficient	100% load	/	±0.02	/	%/°C
Overcurrent protection	Input voltage range	110	140	190	%I _o
Short circuit protection	Continuous, self-recovery				

Notes:

1. ripple and noise are measured at 20 MHz BW by "parallel cable" method with 1 μF ceramic and 10 μF electrolytic capacitors on the output.

COMPREHENSIVE

Item	Conditions/Description	Min	Typ	Max	Units
Isolation voltage	input to output for 1 minute at 1 mA max.	1500	/	/	VDC
Isolation resistance	Input to output, insulation voltage 500 VDC	1000	/	/	MΩ
Isolation capacitor	Input-Output, 100kHz/0.1V	/	1000	/	pF
Operating temperature	Use with derating when temperature is ≥71°C, see derating curve chart 1	-40	/	85	
Storage temperature		-40	/	125	°C
Working shell temperature rise	at full load, T _a =25°C	/	25	/	
Welding Temperature	Manual-welding, Operation time 3-5 seconds	/	/	300	
	Wave soldering, Operation time 5-10 seconds	/	/	260	
Storage humidity	non-condensing	5	/	95	%
Switching frequency	Full load, input nominal voltage	/	300	/	KHz
MTBF	MIL-HDBK-217F @ 25°C	/	1000	/	Khours
Cooling method	Natural air cooling				
Dimensions	32.00 x 20.00 x 10.80mm (1.260 x 0.787 x 0.425 inch)				
Weight	12.0g (Typ.)				
Case material	Aluminum alloy				

EMC

Item	Conditions/Description		
EMI	CE	CISPR32/EN55032 CLASS B (For recommended circuits, see Figure 3-②)	
	RE	CISPR32/EN55032 CLASS B (For recommended circuits, see Figure 3-②)	
EMS	Electrostatic Discharge	IEC/EN61000-4-2 Contact ±4kV	perf. Criteria B
	Radiated Immunity	IEC/EN61000-4-3 10V/m	perf. Criteria A
	Pulse group Immunity	IEC/EN61000-4-4 ±2kV(For recommended circuits, see Figure 3-①)	perf. Criteria B
	Surge Immunity	IEC/EN61000-4-5 line to line ±2kV (For recommended circuits, see Figure 3-③)	perf. Criteria B
	Conducted disturbance immunity	IEC/EN61000-4-6 3 Vr.m.s	perf. Criteria A
	Voltage dips, and short-term interruptions immunity	IEC/EN61000-4-29 0%-70%	perf. Criteria B

Product characteristic curve

(Figure 1) Temperature curve

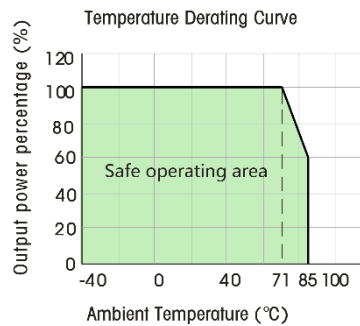

Design reference

1. General application circuits

All DC/DC converters in this series are tested according to the generally recommended circuit (as shown in Figure 2) before leaving the factory.

If further reduction of input and output ripple is required, the external filter capacitors Cin and Cout connected to the input and output terminals can be appropriately increased in capacitance, but the capacitance value should not exceed the maximum capacitive load of the product, otherwise it may cause startup issues. Under the condition of ensuring safe and reliable operation, the recommended capacitance values are as follows (Table 1). For applications with actual output power less than 0.5W, it is recommended not to connect external capacitors.

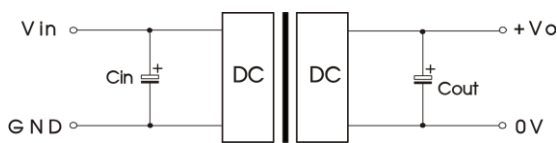

(Figure 2)

Input voltag(Vdc)	Capacitance Cin	Output voltag(Vdc)	Capacitance Cout
5	100uF/16V	5/9	10uF/16V
12	100uF/35V		
24	100uF/50V	12/15	10uF/25V
48	10~47uF/100V	24	10uF/50V

(Table 1)

2. EMC Recommended Application Circuits (Parameters are shown in Table 2)

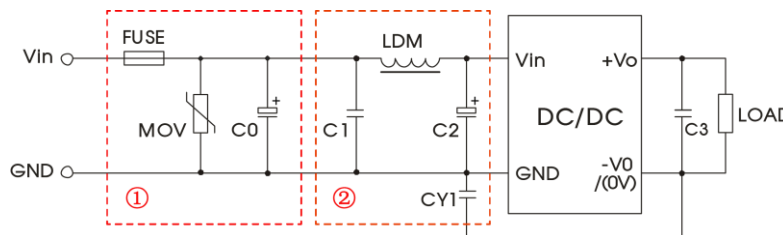

(Figure 3)EMC Recommended Circuit

Vin(VDC)	5	12	24	48
FUSE	Slow-blow fuse, selected based on the user's actual input current			
MOV	/	14D330K	14D470K	14D101K
C0	2200μF/25V	1000μF/35V	1000μF/50V	680μF/100V
C1	4.7μF/50V	1μF/50V	1μF/50V	1μF/100V
LDM	4.7μH			
C2	100μF/25V	100μF/35V	100μF/50V	100μF/100V
C3	Refer to the Cout parameter in Figure 2			
CY	1nF/400VAC			

(Table 2) Recommended Application Circuit Parameters of EMC

Note:

1. Part ① in Figure 3 is used for EMS testing; part ② is used for EMI filtering, which can be selected according to requirements;
2. If the component in the diagram does not have parameter descriptions attached, this component is not required in the peripheral circuit of this model.

Ripple and Noise Testing Reference

Refer to the following circuit to test ripple and noise

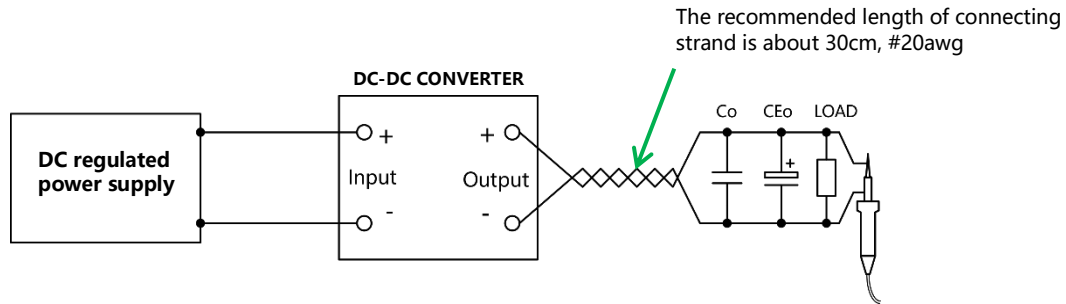

Co	0.1uF ceramic capacitor, the voltage level is 3 times of the output voltage of DC / DC converter.
CE1	10uF electrolytic capacitor, the rated voltage is 1.5 times of the output voltage of DC / DC converter.
LOAD	Resistive load to DC / DC converter shall be connected through stranded wire.

Note: since the ground clamp of the oscilloscope will absorb various high-frequency noise interference measurement results, in order to shield the interference, the proximity test method can be used for measurement. The actual test ripple and noise will vary due to different circuits, external components and instruments.

MECHANICAL DRAWING

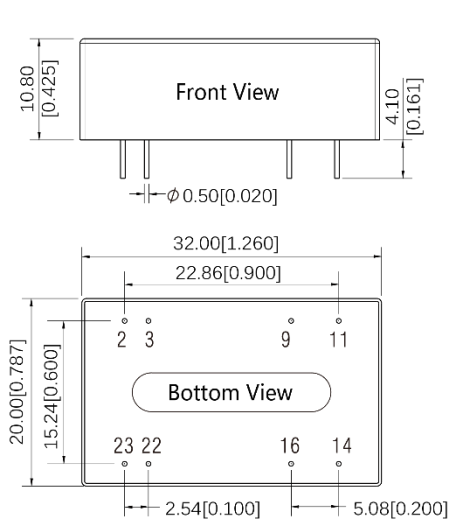

Dimension unit: mm [inch]
Pin tolerance: ± 0.10 [± 0.004]
Other tolerances: ± 0.50 [± 0.020]

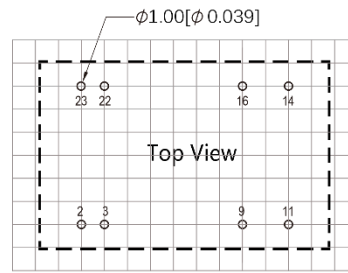

Grid distance: 2.54×2.54 mm
Recommended PCB footprint (top view)

PIN CONNECTIONS	
2,3	GND
9	No Pin
11	NC
14	+Vo
16	0V
22,23	Vin

NC: Cannot be connected to any circuit

Note:

1. Qituo technology reserves the right to change the product at any time without notice;
2. The product shall be provided with a 3-year warranty period;
3. Unless otherwise specified, the products in this manual are not authorized to be used for key components of equipment requiring high reliability, so as not to affect the safety or effectiveness of the device;
4. All parameters in this manual are measured under indoor $t_a=25$ °C, humidity <75%, nominal input voltage and output rated load;